

WVC600 servers

WVC600 Micro-inverter solar grid system (Power line communications)

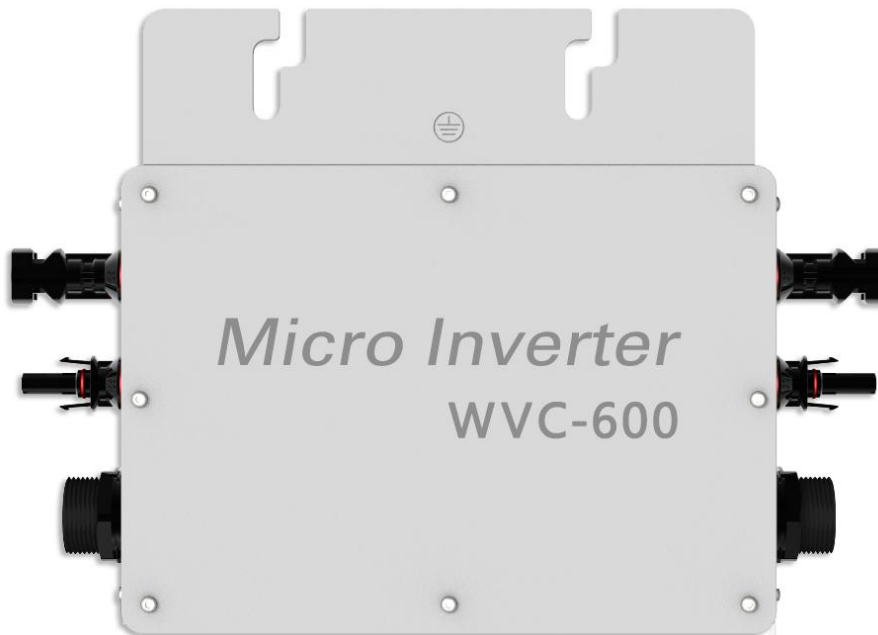

WVC600 Using IP65 waterproof streamline design, Can effectively prevent rainwater on the surface erosion, Built-in high-performance Maximum Power Point Tracking (MPPT) Function, Better able to track changes in the solar luminosity and control different output power, Effectively capture and collect sunlight. AC electric power transmission using the reverse transmission technology, Is one of our patented technology, The inverter output power can provide load priority use, Extra electricity to the grid, Efficient use of the inverter to the power emitted, Electricity transmission rate of up to 99%.

Communication using two modes, Between the inverter and Collector Using power line carrier communication signals, Collector with a PC or other devices to communicate Using RS232 serial port/ WIFI wireless communication. Intelligent monitoring systems, The inverter can collect real-time data, Inverter can be controlled startup / shutdown / power regulation.

Features:

- High performance maximum power point tracking (MPPT)
- Reverse power transmission
- Intelligent monitoring management
- Input /output is fully isolated to protect the electrical safety
- Multiple parallel stacking
- Digital control system
- Simplify maintenance (user serviceable)
- Operation and maintenance costs low

WVC600 servers

- Flexible installation

WVC600 Parameters

Input Data		WVC600-120VAC/230VAC	
Recommended input power		500-600Watt	
Recommend the use of PV modules		2*300W/V _{mp} >34V/V _{oc} <50V	
Maximum input DC voltage		50V	
Peak power tracking voltage		25-40V	
Operating Voltage Range		17-50V	
Min / Max start voltage		22-50V	
Maximum DC short current		40A	
Maximum Input Current		25A	
Output Data	@120VAC	@230VAC	
Peak power output	600Watt	600Watt	
Rated output power	550Watt	550Watt	
Rated output current	4.58A	2.3A	
Rated voltage range	80-160VAC	180-260VAC	
Rated frequency range	57-62.5Hz	47-52.5Hz	
Power factor	>96%	>96%	
Maximum units per branch circuit	6PCS (Single-phase)	12PCS (Single-phase)	
Output Efficiency	@120VAC	@230VAC	
Static MPPT efficiency	99.5%	99.5%	
Maximum output efficiency	92%	92%	
Night time power consumption	<50mW Max	<70mW Max	
THD	<5%	<5%	
Exterior			
Ambient temperature	-40°C to +60°C		
Operating temperature range (inverter inside)	-40°C to +82°C		
Dimensions (WxHxD)	289mm×200mm×38mm		
Weight	1.53kg		
Waterproof Rating	IP65		
Cooling	Self-cooling		
Feature			
Communication Mode	Power Line		
Power transmission mode	Reverse transfer, load priority		
Monitoring System	Lifetime free		
Electromagnetic compatibility	EN50081. part1 EN50082. part1		
Grid disturbance	EN61000-3-2 Safety EN62109		
Grid detection	DIN VDE 1026 UL1741		
Certificate	CEC, CE National patent technology		

* **Note:** The monitoring software can monitor multiple threads simultaneously 6 PCS power line acquisition simultaneously monitor 600 inverters.

- 1) Each WVC Power Line Modem monitoring 100 inverters
- 2) Monitoring system simultaneously collect real-time data from 6 WVC power line Modem by 6 threads

WVC600 servers

PV micro-inverter system components System Block Diagram

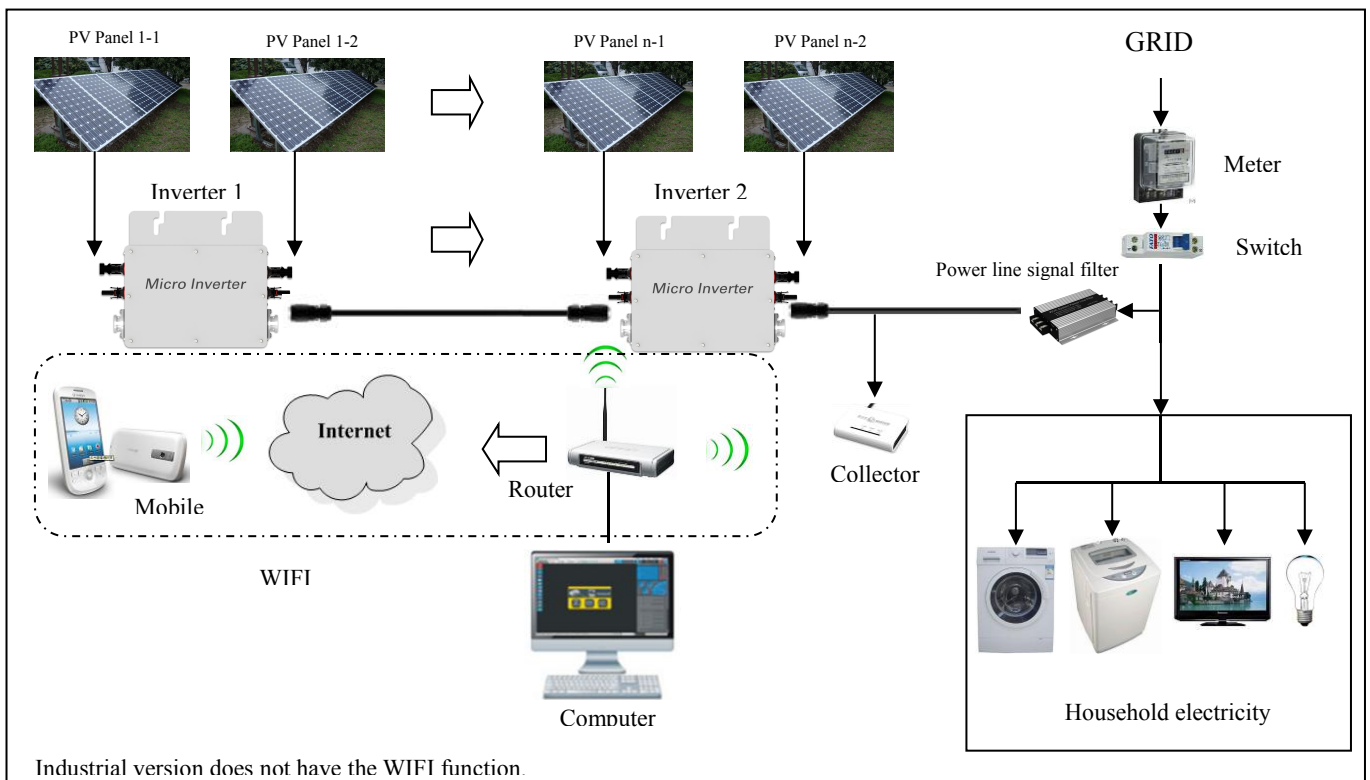

System Description

Micro-grid inverter system components

Components of Micro-inverter system

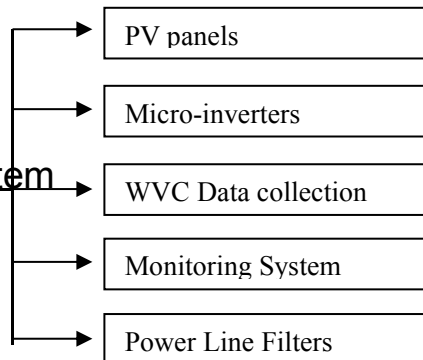

WVC600 servers

In summary, Micro-inverter system is simpler, more convenient installation.

High performance maximum power point tracking (MPPT)

Powerful MPPT algorithm, Optimize the power from the solar panels to collect, Accurately capture and lock the maximum output power point, A substantial increase in output power greater than 25% or more.

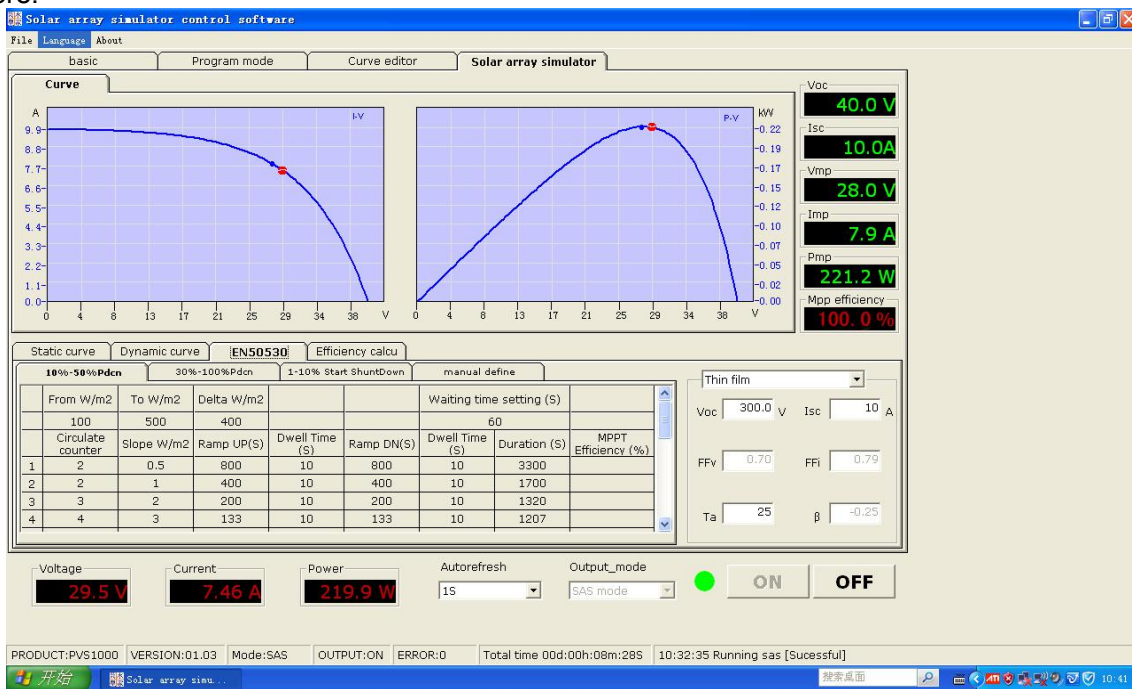

MPPT

Power Output: (Reverse power transmission)

Reverse efficient power transmission technology, Patented technology, The inverter power transmission in the reverse direction, Automatic detection circuit load and using priority, Additional power transmitted to the grid, Power transmission rate up to 99.9%. Higher output efficiency in photovoltaic application system manipulation.

WVC600 servers

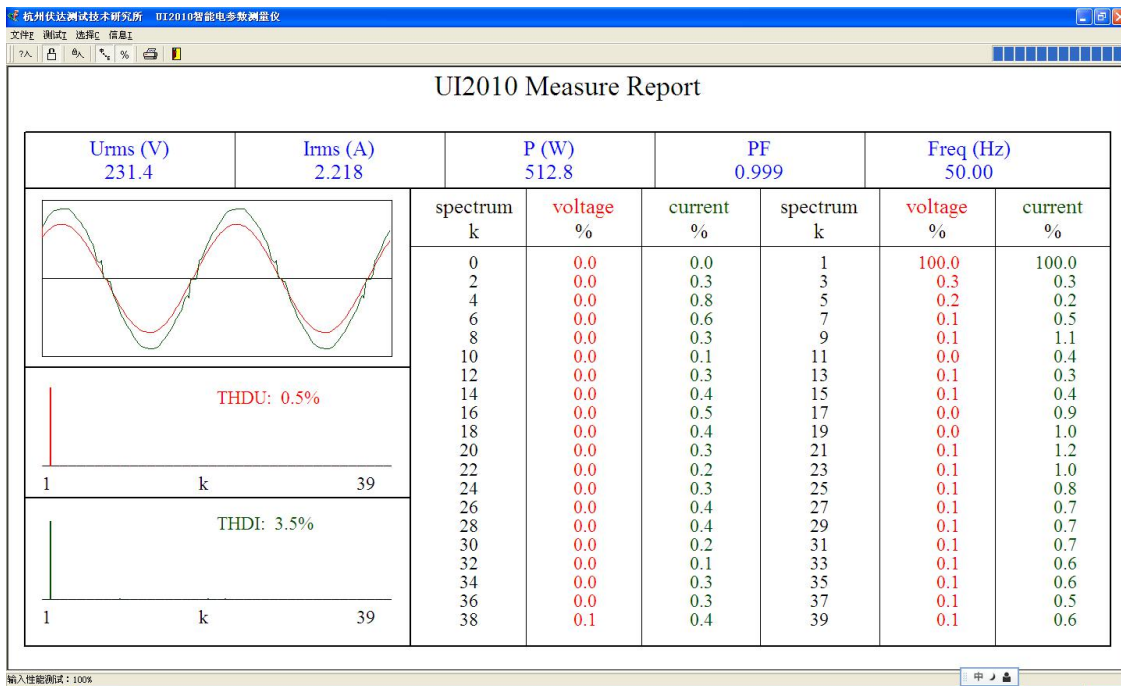

THD

Electrical schematics

Single-phase electrical schematics

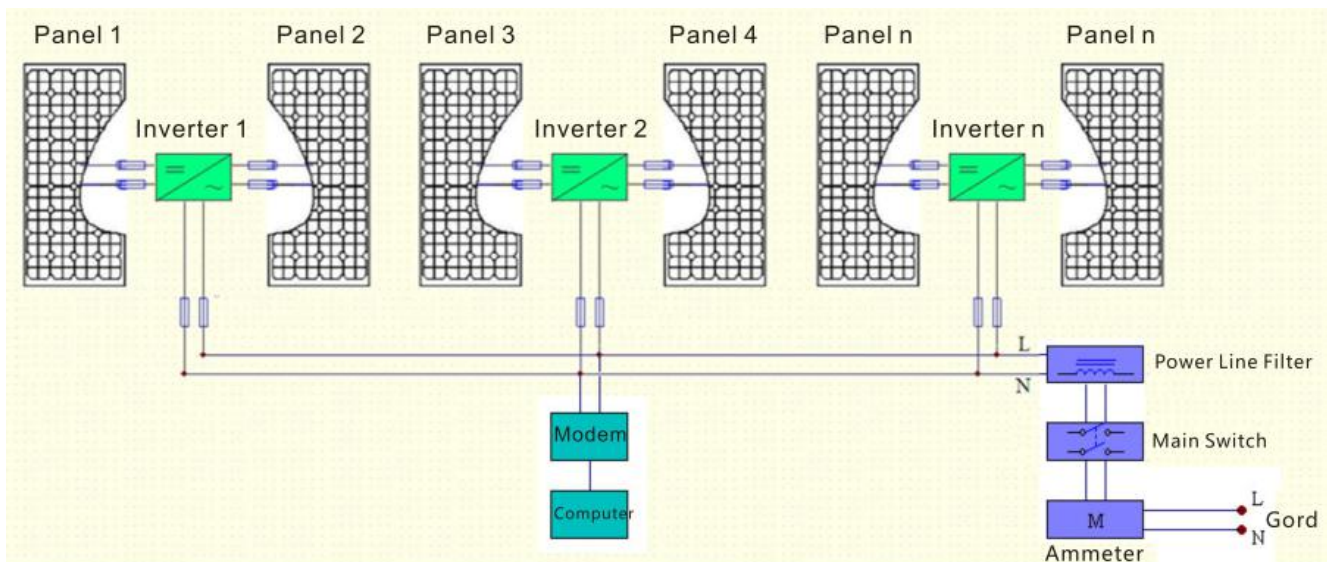

Three-phase electrical schematics

WVC600 servers

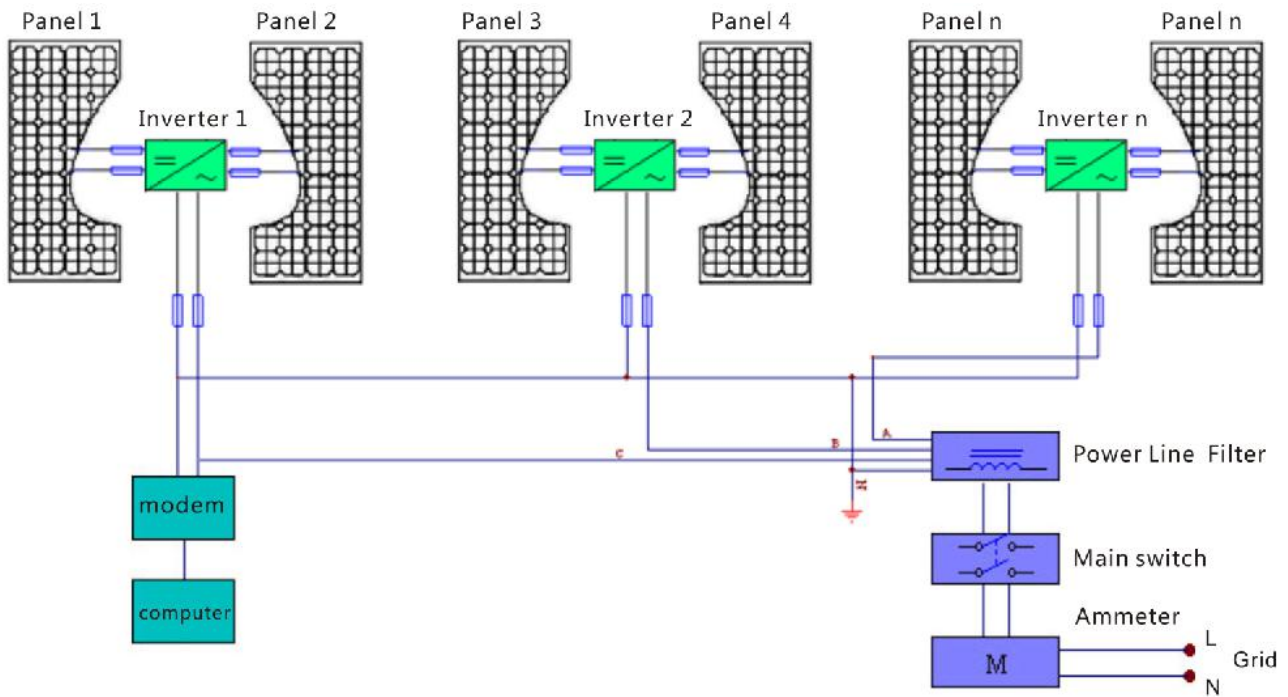

WVC600 servers



WVC600 servers



WVC600 servers

WVC600 Using IP65 waterproof streamline design, Can effectively prevent rainwater on the surface erosion, Built-in high-performance Maximum Power Point Tracking (MPPT) Function, Better able to track changes in the solar luminosity and control different output power, Effectively capture and collect sunlight. AC electric power transmission using the reverse transmission technology, Is one of our patented technology, The inverter output power can provide load priority use, Extra electricity to the grid, Efficient use of the inverter to the power emitted, Electricity transmission rate of up to 99%.



- ① PV Panel Input 1
- ② PV Panel Input 2
- ③ AC Input –
- ④ AC Output – Connect to the Next
- ⑤ LED Display

WVC600 servers

Installation and connection

WVC600 Series Solar Inverter very easy to install, No need for project professionals can also install. Whether installation or maintenance are very simple, No maintenance.

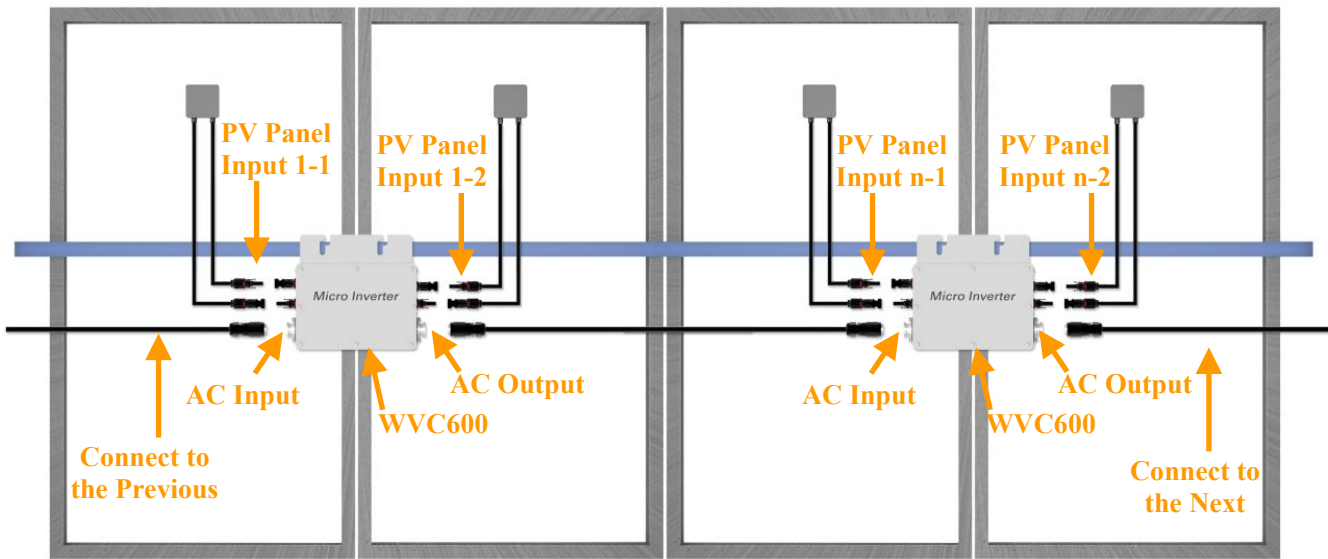

Monitoring System

The Monitoring System KDM is a product designed specifically for WVC.

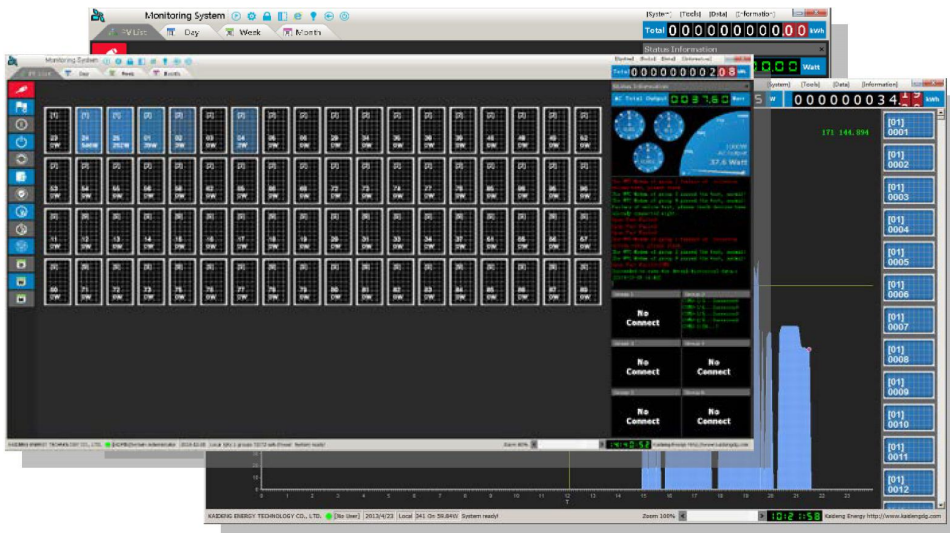

WVC600 servers

Data collection

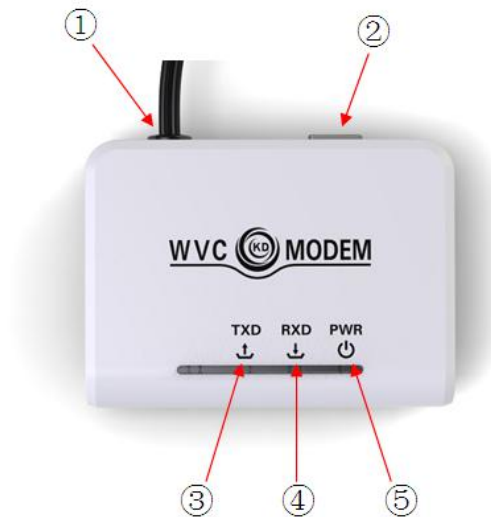

- ① AC power input, power line signal input
- ② RS232 serial data port
- ③ Data Send LED Indicator (blue)
- ④ Data Receive LED indicator (blue)
- ⑤ Power Indicator

Why is the use of micro-inverter?

1. The transition from a centralized to a distributed inverter optimizes energy collection.
2. The converter module integrated into the solar panels can reduce installation costs.
3. By reducing the temperature of the converter and remove the fan, you can enhance system reliability from 5 years to 20 years.
4. Soft switch technology to replace hard-switching technology can improve efficiency and reduce heat dissipation.
5. From cottage industry to mass production, standardized design (hardware and software) to improve reliability and reduce costs.
6. Using a special capacitor (due to the high failure rate). Design requires a higher voltage to reduce the current, we use a special electrolytic capacitors.
7. The converter can be connected to the grid to eliminate the need for many battery applications. The high price of batteries, require maintenance, life expectancy is shorter.
8. Work required micro-inverter power increasingly smaller (only a few hundred watts), which can reduce the internal temperature and improve reliability.
9. Micro-inverter solar inverter system needs to deal with a lot of a particular power level, in order to increase production, thereby reducing costs.

WVC600 servers

Power line signal filter



- ① N-pole AC output
- ② N-pole AC input
- ③ L-pole AC input
- ④ Output Ground
- ⑤ L-pole AC output
- ⑥ Fixed
- ⑦ Input Ground

Contact Us:

WVC600 servers