

TOF050F

Time-of-Flight ranging Sensor-50CM

1. Description

TOF050F ranging sensor is a laser ranging module designed and manufactured based on VL6180, which provides accurate and repeatable short-distance measurement function. Thanks to the highly integrated infrared transmitting and receiving mechanism and ST's innovative FlightSense technology, faster and more accurate distance measurement and higher ambient light immunity can be achieved.

TOF050F supports serial port mode, serial port simulation Modbus mode, and IIC mode at the same time, which is well adapted to various application scenarios.

It is equipped with a host computer for easy debugging.

TOF050F has a range of up to 50cm, and can choose high-precision or long-distance test mode according to needs, making it more flexible. The ranges are as follows:

Item	Attributes	Data	Period
0	High	100ms	20cm
1	Middle	100ms	40cm
2	Long	100ms	50cm

Features

- 850nm laser meets the Class 1 operating conditions specified in the third edition of IEC 60825-1:2014
- Sensor size (20×16.8×6.0mm)
- The maximum measurement distance indoors can reach 0.5 meters, the accuracy is within 5%
- The measurement range has nothing to do with the reflectivity of the target object
- Can work in high infrared light environment
- High optical crosstalk compensation
- Measurement time is less than 30ms
- No need for additional optics
- Single power supply
- Standard TTL level serial port I2C
- High optical crosstalk compensation

Applications

- High-speed autofocus
- Video continuous auto focus
- User detection of computers and other equipment
- Obstacle detection
- Automatic gesture recognition of white goods (such as faucets, refrigerators, etc.)

2. Characteristic description

2.1 Structural

volume	18mmX17mmX6mm(L*W*H)
Fixing	d=2mm,Spacing14/11mm
weight	3g

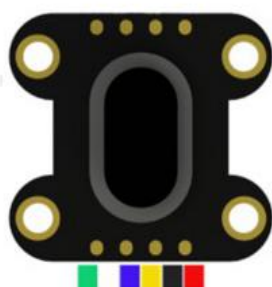

- TXD
- RXD
- SCL
- SDA
- GND
- VIN

TOF050F

2.2 Electrical performance

Project	Element	Minimum	Typical	Maximum	Unit
Measuring range	High precision	/	200	/	mm
	Middle distance	/	400	/	mm
	Long distance	/	500	600	mm
Operating Voltage	/	3.0	3.3	5	V
Working current	/	/	/	40	mA
Operating temperature	/	-20	/	70	°C
Storage temperature	/	-40	/	80	°C

2.3 Optical parameters

Items	Element	Minimum	Typical	Max	Unit
Vertical emission laser peak	/	/	850	/	nm
Vertical emission laser peak	/	/	38	/	mA

2.4 Pin description

Pin	Name	Attributes	Function
1	VIN	/	VIN+ 3~5V
2	GND	/	GNDGND
3	SDA	Input /Output	IIC clock port
4	SCL	Input	IIC data port
5	RX	Input	Serial input TTL level RXD
6	TX	Output	Serial output TTL level TXD

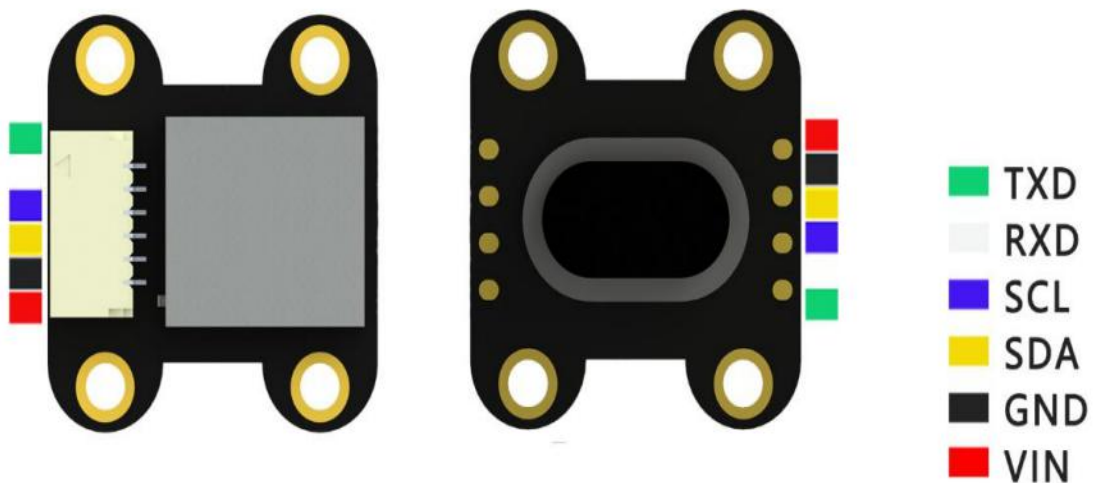

3. Operating mode

Mode	Switch	Detailed
Serial port mode (default)	No need to switch	Single-machine serial port data sending and receiving, actually follow the Modbus_RTU protocol, and the supporting host computer can facilitate debugging and setting
Modbus protocol mode		The standard Modbus_RTU can be used to access registers to facilitate interaction with industrial equipment. Separate addresses can be set, and broadcast addresses can be shared. It is very convenient to realize multi-module cooperative work.
IIC	Command switch	The module gives up the IIC bus and can directly use the IIC to access the sensor

3.1 Serial + modbus mode

Serial communication protocol description	
Bits per Second :	115200
Data Bits :	8
Parity :	None
Stop bits :	1
Stop bits :	None

3.1.1 modbus Format description

Read command (take slave 0x01 as an example)							
Slave addr	Function number	Register High	Register Low addr	Data H	Data L	CRC Check L	CRC Check H
DR	RW	RegH	RegL	DH	DL	CL	CH
0x01	0x03	RegH	RegL	DH	DL	CL	CH
Sensor return							
Slave addr	Function number	Number of data bytes	Data byte 1 high bit	Data byte 1 low bit	...	CRC Check L	CRC Check H
DR	RW	D	DATA1H	DATA1L	...	CL	CH
0x01	0x03	D	DATA1H	DATA1L	...	CL	CH

Example: Host 01 03 00 10 00 01 85 CF

Read the ranging value of 1 slave

Module reply: 01 03 02 00 15 79 8B

Ranging value is 0x0015 (21mm)

Write command (take slave 0x01 as an example)							
Slave addr	Function number	Register High	Register Low addr	Data H	Data L	CRC Check L	CRC Check H
DR	RW	RegH	RegL	DH	DL	CL	CH
0x01	0x06	RegH	RegL	DH	DL	CL	CH
Sensor return							
Slave addr	Function number	Number of data bytes	Data byte 1 high bit	Data byte 1 low bit	...	CRC Check L	CRC Check H
DR	RW	RegH	RegL	DH	DL	CL	CH
0x01	0x06	RegH	RegL	DH	DL	CL	CH

Example: Host sends: 01 06 00 04 00 01 09 CB Set the ranging mode of 1 slave to high precision
Module reply: 01 06 00 04 00 01 09 CB Set successful response

Special note: CRC check rule is CRC-16/MODBUS

The check code can be generated by the existing CRC check code generator or the matching module, which is convenient to use.

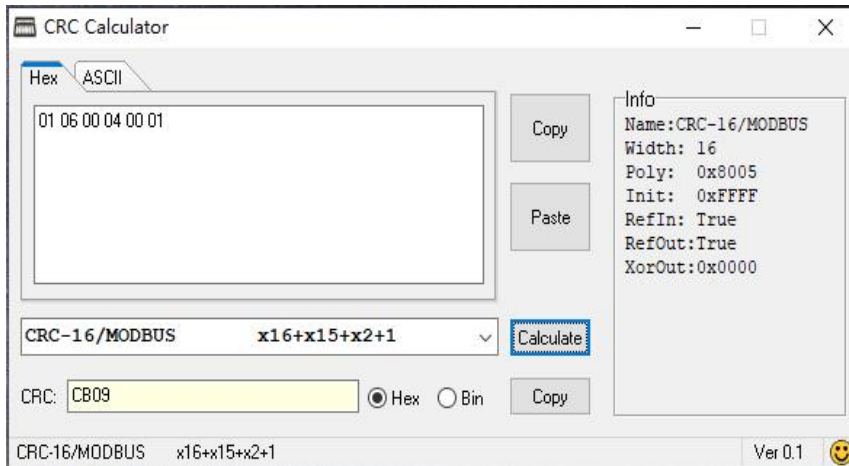

3.1.2 Register list

Category	Data addr	Data	Function	W/R
Special register	0x0001	0xAA55	Restore default parameters	write
		0x1000	Reboot	
		0x0000	Test communication	
Device address register	0x0002	0XXXX	0 : Broadcast addr	Read & write
Baud rate register	0x0003	0x0001	1:38400	Read & write
		0x0002	2:9600	
		0x0003/other	Others:115200	
Range register	0x0004	0x0001	1: High precision, 100ms, 0.2m	Read & write
		0x0002	2: Middle distance, 100ms, 0.4m	
		0x0003	3: Long distance, 100ms, 0.5m	
Continuous output control register	0x0005	0x0000	0: no self-output	Read & write
		0XXXX	XX:XXms	
Load calibration register	0x0006	0x0000	0: do not load	Read & write
		0x0001	1: load	
Offset correction value register	0x0007	0XXXX	Offset correction value	Read & write
xtalk correction value register	0x0008	0XXXX	xtalk correction value	Read & write
Disable iic enable register	0x0009	0x0000	0: not prohibited (default)	Read & write
		0x0001	1: Prohibited (MCU releases)	
Measurement	0x0010	0x0001	Distance value: mm	Read
offset calibration	0x0020	0XXXX	xx:The actual value is xx, 5cm is recommended	write
xtalk calibration register	0x0021	0XXXX	xx:The actual value is xx	write

Gray	Indicates that the setting needs to be restarted to take effect		
Application examples	Set mode	01 06 00 04 00 01 09 CB	Set the distance measurement mode of unit 1 to high precision
	Read distance value	01 03 00 10 00 01 85 CF	Read the ranging value of No. 1
	Module restart	02 06 00 01 10 00 D5 F9	No. 2 slave module restarts
	Change the slave	01 06 00 02 00 04 29 C9	Slave 1 becomes slave 4
	Set the baud rate	04 06 00 03 00 02 F8 5E	Set the baud rate of No. 4 machine to 9600, need to restart to take effect
	Automatic output	01 06 00 05 01 F4 99 DC	Set the No. 1 machine to automatically output the measured value in 500ms
	IIC mode	01 06 00 09 00 01 98 08	Set machine 1 to IIC mode

3.2 IIC mode

When set to IIC mode, the MCU releases the VL6180 sensor IIC bus. SDA and SCL are directly connected to the sensor (SDA and SCL are pulled up by internal 10K resistors). For specific data reading, please refer to the VL6180 data manual.

4 Commissioning instructions

4.1 Serial debugging instructions

4.1.1 Hardware connection

To connect to a computer, a serial port module with USB to TTL level is required. **Note that TX and RX need to cross.**

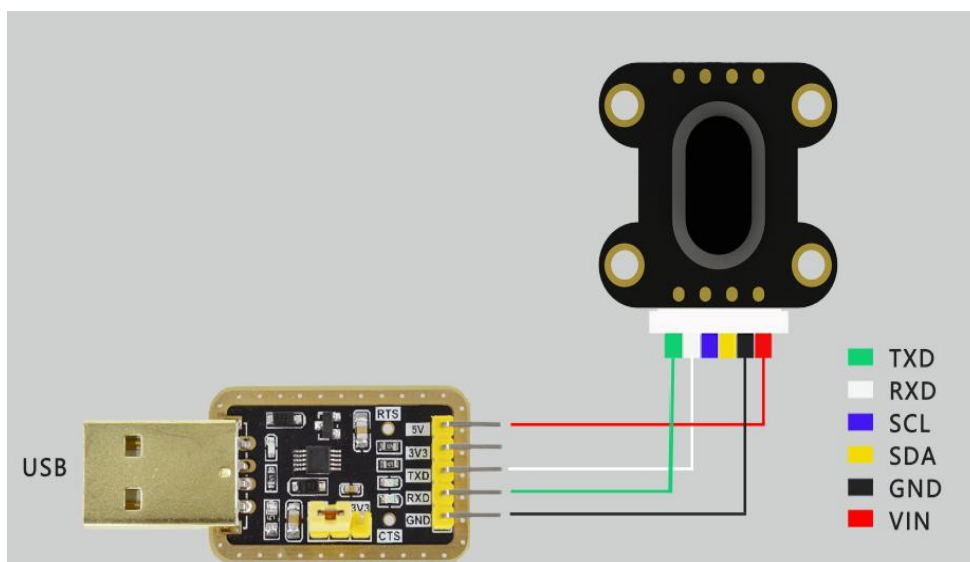

4.1.2 Serial software debugging

After connecting with the USB to TTL module, plug the serial port module into the computer USB port. Make sure to find the corresponding COM port after installing the driver of the serial port module. Open the serial port debugging software, connect for the first time, set the baud rate to the default 115200, you must select "HEX display" and "HEX send", and select "time stamp and sub-package display" as required. Finally, open the serial port and perform communication configuration according to the order of instructions from top to bottom as shown in the figure below to complete a complete debugging process. After setting, the ranging module works in high-precision mode and outputs a ranging value every 500ms.

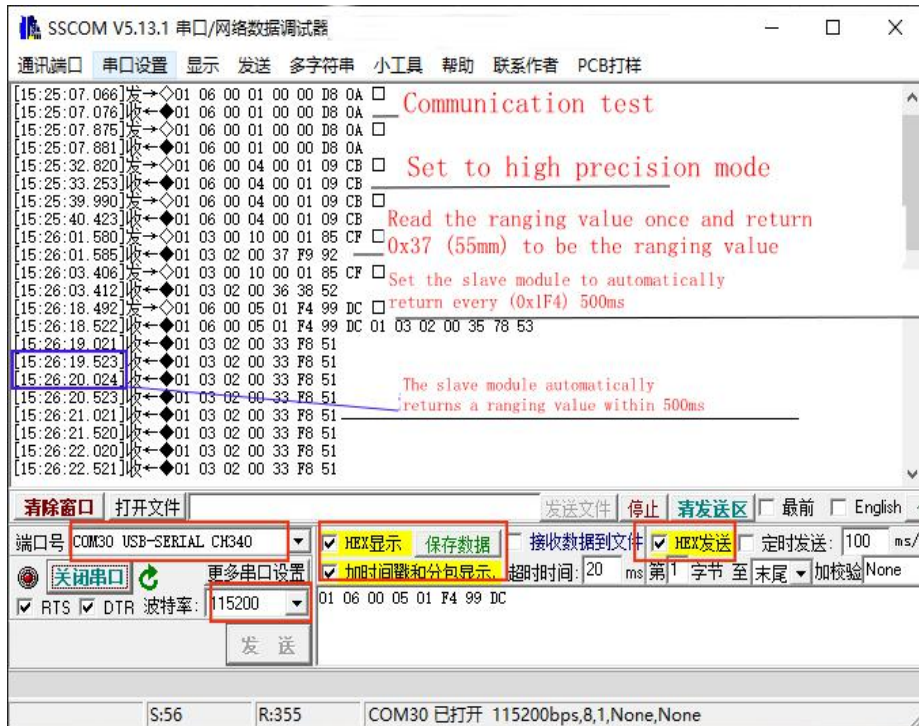

4.2 Supporting host computer debugging instructions

4.2.1 Hardware connection

To connect to a computer, a serial port module with USB to TTL level is required. Note that TX and RX need to cross. Refer to section 4.1.1 for details.

4.2.2 PC debugging (take TOF200H as an example)

After connecting with the USB to TTL module, plug the serial port module into the computer USB port. Make sure to find the corresponding COM port after installing the driver of the serial port module. Open the host computer software of the TOF ranging sensor, connect for the first time, set the baud rate to the default 115200, select the corresponding model system in "System Configuration", and click "Start". You can see the real-time display of the measured distance column in the "status display", and the measured value is constantly refreshed as the actual distance changes.

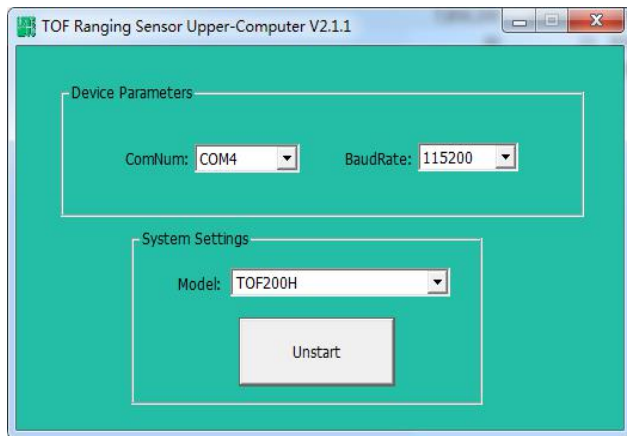

TOF200H Ranging Computer		
STATE: setting		
Range		
名称 name	数值 Value	单位 Unit
Rang_nm	65	mm
Rang_cm	6.5	cm
Rang_dm	0.65	dm
Rang_m	0.065	m
running time		
名称	数值	单位
intvTime	1	ms
systemMs	139.562	s
rtStatusTime	19700101.08:02:19	ymd:h:m:s
rtStatus	0x0	1ok

Select the parameter configuration column, you can see that there are 4 groups of parameters for users to set or observe, which is convenient for debugging. Storage parameter 1 is a commonly used setting function. The user can set the device address, baud rate, distance mode, output cycle, etc., and the parameters are saved immediately after setting and are effective when power off. Setting method: directly input the value of the required option in the value of the corresponding function line, and press Enter.

The device address is written directly; please refer to the instruction set for the parameters represented by the specific options of the baud rate/output cycle, for example, the baud rate 0 represents the default 115200; the output cycle is also written directly in ms (note that the output cycle is changed here) It is the serial port automatic output cycle, and the upper computer reads the data cycle is fixed). The correction K can specify the multiple of the output distance and the actual distance, which is suitable for special purposes. In the "Load Calibration" and "Disable iic" function lines, the value 1 means enable and 0 means disable.

Storage parameter 2 is generally used for observation. For specific values, refer to the chip specification.

The last two calibration parameter settings apply to the calibration function. For offset calibration, it is recommended to use a white target object with 88% reflectivity in dark conditions and calibrate at an actual distance of 10cm. That is, the object is placed at the actual distance of 10cm, enter 10cm in the offset calibration function line, press Enter to start the calibration, and wait for the parameter display to return to normal to complete the calibration. The actual module has been calibrated once with a 10cm offset before leaving the factory and can be used directly. The xtalk calibration is mainly to correct the crosstalk factor generated by the cover window in front of the probe. This module has been equipped with a dedicated glass cover sheet and has been calibrated at the factory. When users need to use without cover sheet or use other cover windows, this function can be used for crosstalk calibration. The specific method is to recommend the use of a gray target with 17% reflectivity. The crosstalk distance value needs to refer to the chip specification and the actual use environment. After selection, refer to the upper computer

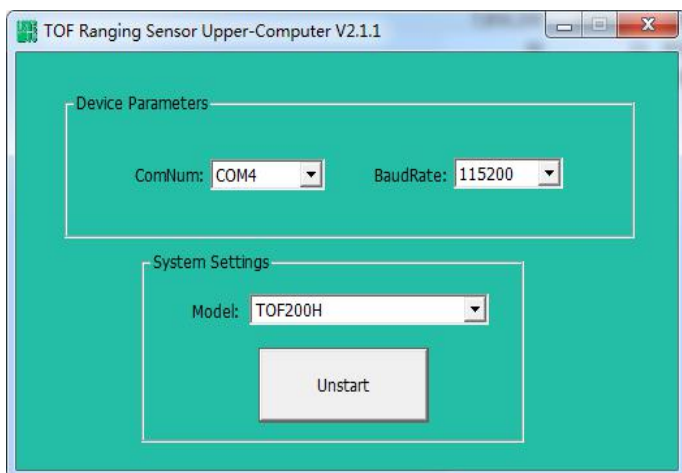

TOF200H Ranging Computer		
STATE: setting		
NVM1		
名称	数值	单位
Device addr	0x1	
BundRate	0	
Ranging mod	1	
Output cycle	0	ms
With calibration	1	
Multiple K	1	
Ban IIC	0	
NVM2		
名称	数值	单位
Offset parameter	0	
Offset target	14	cm
xTalk parameter	0	
xTalk target	10	cm
Offset calibration		
名称	数值	单位
Offset target	14	cm
xtalk calibration		
名称	数值	单位
xtalk target	10	cm

4.3 MCU connection

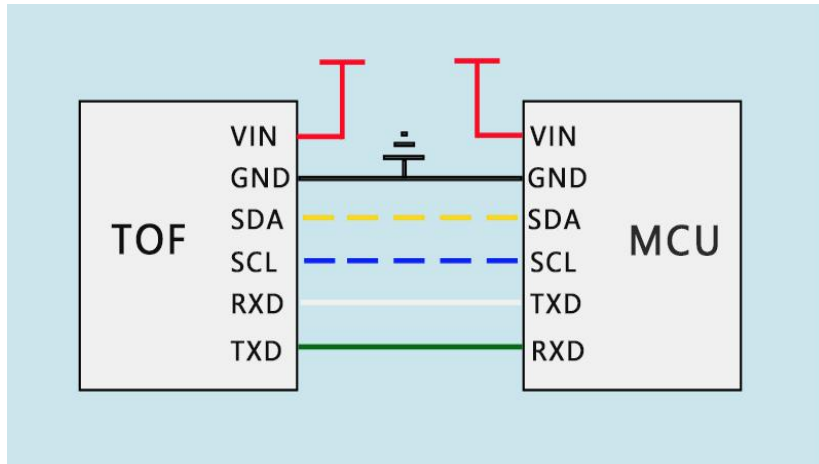

4.3.1 arduino

Connect UNO and TOF050H ranging module according to the wiring diagram, open the matching Uno test program, and upload it to the UNO development board. The test results are shown below.

Wiring diagram

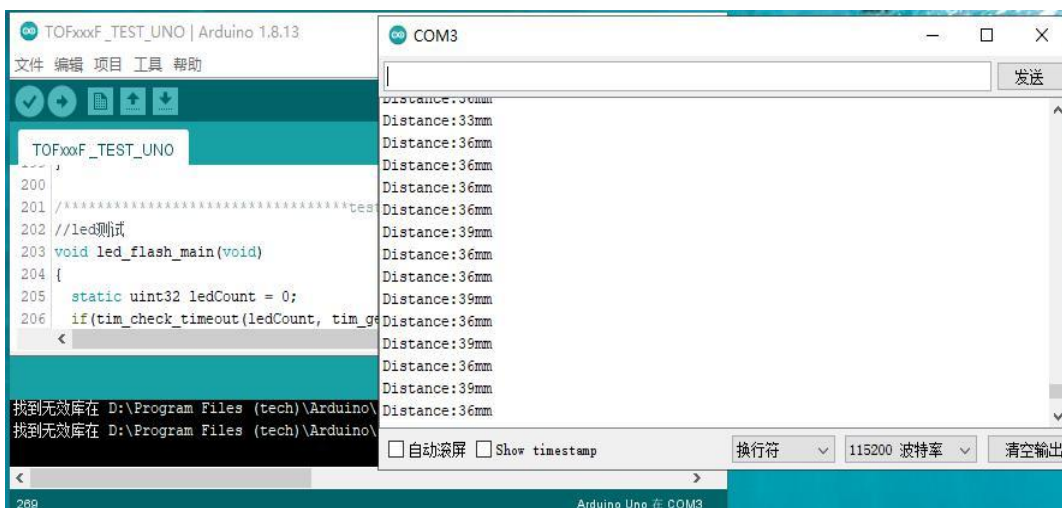
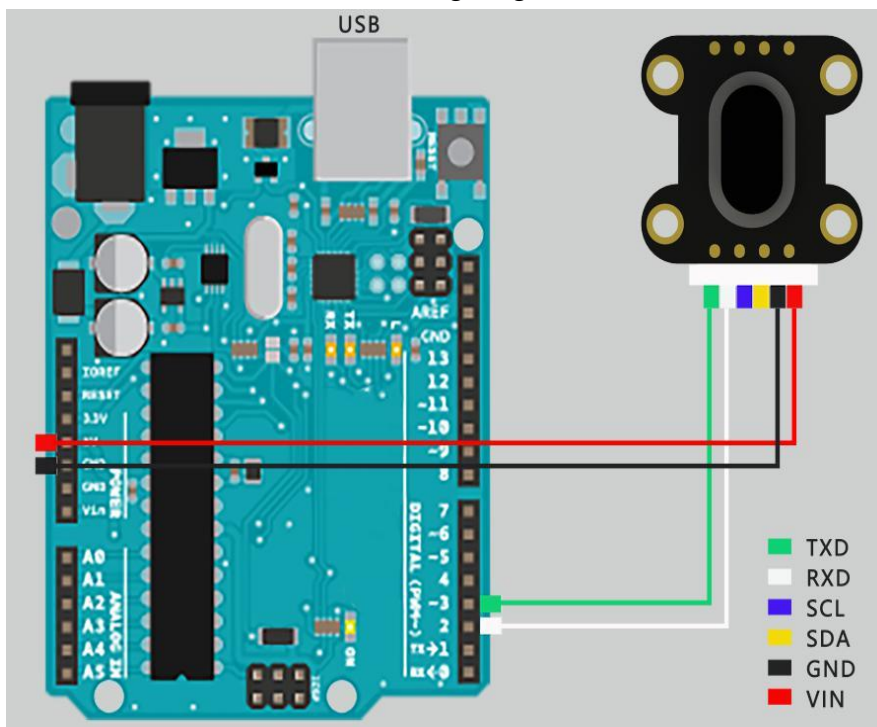

4.3.2 stm32 demo

Connect STM32 and TOF050F ranging module according to the wiring diagram, open the supporting STM32 test program, and upload it to the STM32 development board. The test

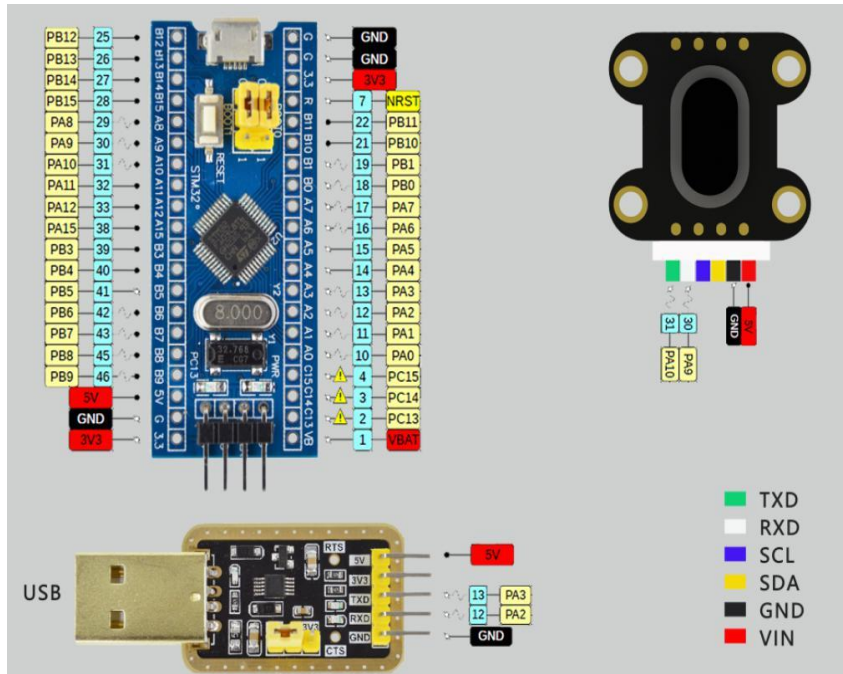

4.3.3 Raspberry Pi demo

For the wiring method, please refer to the serial port debugging section, connect the serial port module with TOFXXXH, insert it into the USB port of the Raspberry Pi, and execute the TOFXXX_TEST.py file on the console. The effect is as follows:

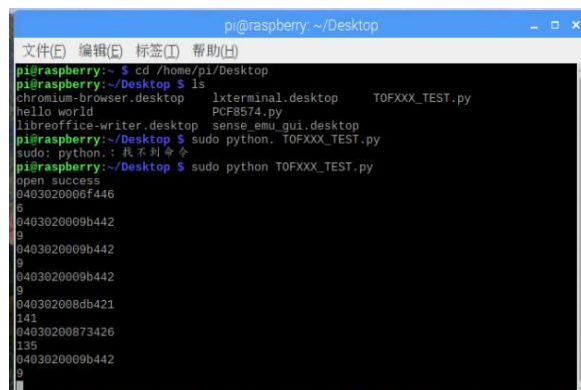

4. Detailed

4.1 Measurement condition

In all measurement tables in the document, it is considered that the full Field Of View (FOV) is covered. This system FOV is 25 degrees. The height of the target must meet this condition.

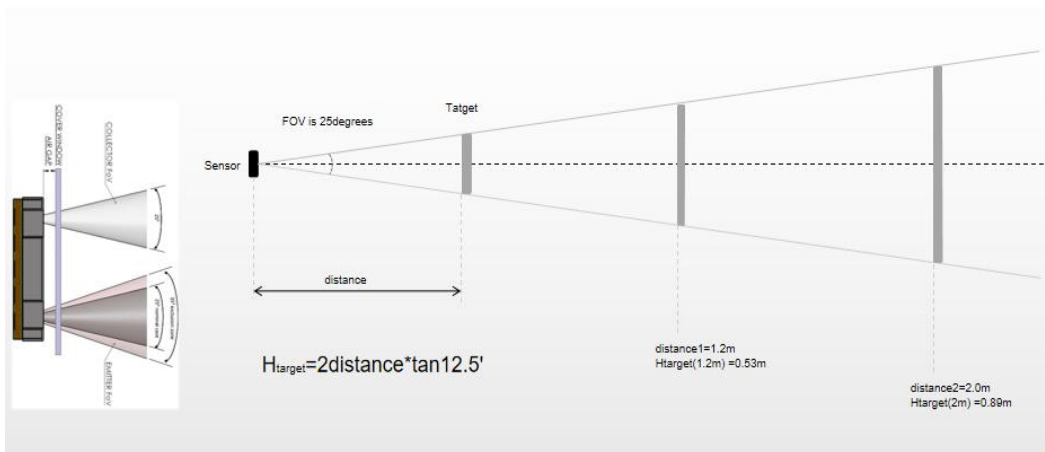

4.2 Ranging

Ranging conditions :

- Targets reflectance used: Grey (17 %), White (88 %)
- Offset correction done at 10 cm from sensor
- Indoor: no infrared
- Outdoor: eq. 5 kLux equivalent sunlight (10 kcps/SPAD)

Parameter	Precision	Minimu	Typical	Max	unit
Minimum distance (indoor)	±5%	1	3		mm
Maximum range distance	±4%	400	500	600	mm
Maximum range distance	±7%	/	400	/	mm
Maximum range distance	±7%	70	200		mm
Maximum range distance	±12%	60	200		mm
Ranging speed (fastest)				100	msec

5. Comes with a cover

It is important to keep the cover window surface finish smooth.

Typically the TOF050H ranging module will be used in conjunction with a window covering.

The cover window serves two main purposes:

1. Provides physical protection of the module, including dust ingress prevention.
2. To provide optical filtering for the module.

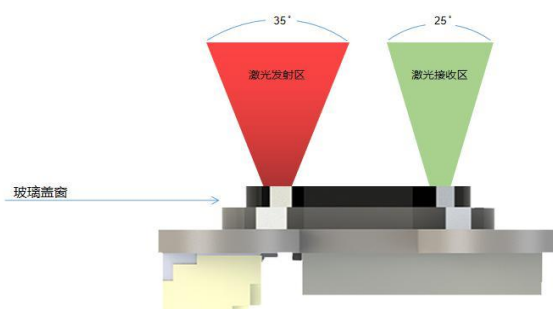

6. Outline Dimensions

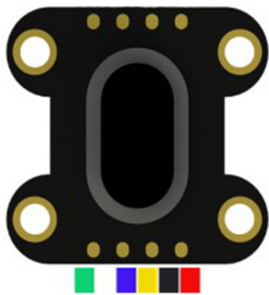
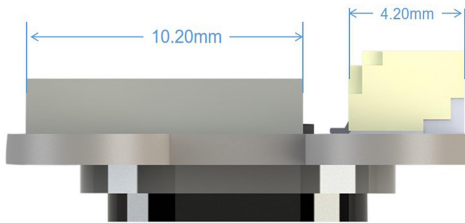
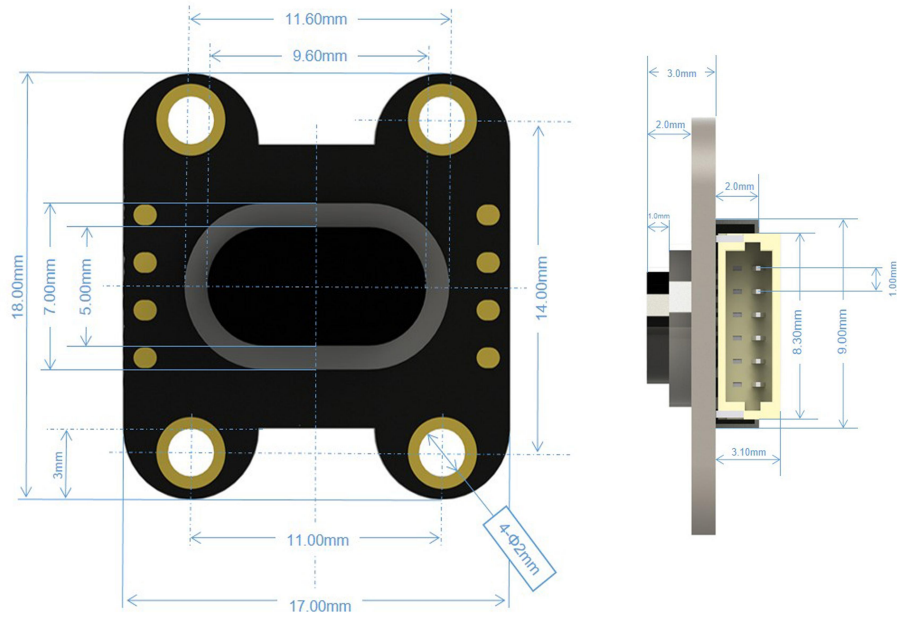

- TXD
- RXD
- SCL
- SDA
- GND
- VIN

TOF050F